

**EH4014/EH4018 Series  
Camera Enclosures**

**Installation/Operation Manual**

**C430M-E (1/95)**

## TABLE OF CONTENTS

<b>Section</b>	<b>Page</b>
1.0 WARNINGS .....	1
2.0 SCOPE .....	2
3.0 DESCRIPTION .....	2
3.1 MODELS .....	3
3.2 OPTIONS .....	3
3.3 RECOMMENDED CABLE SIZE .....	4
3.4 SPECIFICATIONS .....	5
4.0 INSTALLATION .....	6
4.1 CAMERA/LENS INSTALLATION .....	6
4.2 HEATER KIT INSTALLATION .....	7
4.3 BLOWER KIT INSTALLATION .....	7
4.4 INSTALLATION PROCEDURES .....	8
4.5 SUN SHROUD INSTALLATION .....	9
5.0 CARE AND MAINTENANCE .....	9
6.0 EXPLODED ASSEMBLY DIAGRAM/PARTS LIST .....	10
7.0 WARRANTY AND RETURN INFORMATION .....	11

## LIST OF ILLUSTRATIONS

<b>Figure</b>	<b>Page</b>
1 EH4014/EH4018 Dimension Drawing .....	2
2 Heater Bracket and Blower Installation .....	7
3 Heater/Blower Wiring Diagram .....	8
4 Sun Shroud Installation .....	9
5 EH4014/EH4018 Exploded Assembly Diagram .....	10

## REVISION HISTORY

<b><u>Manual #</u></b>	<b><u>Date</u></b>	<b><u>Comments</u></b>
C430M	11/88	Original version.
C430M	4/90	Rev. A. Added EH4014-1/-2, EH4014/BR, EH4014/CH, EH4014/CP, EH4018-1/-2, and BK4000/BK4024 models. Figure 2 revised to show current design. Sections 4.2.1 and 4.2.2 revised to include new cable distances and heater kit installation procedures. Section 7 updated to include additional hardware.
C430M	9/90	Rev. B. Manual revised to include Section 1.1 for the UL compliance and listing.
	11/90	Addendum issued for addition of 230 VAC models.
C430M	11/90	Rev. C. Sections 2.1 thru 2.4, 3.0, 4.2, 4.2.1, and Figures 2 and 3 revised to include the addition of 230 VAC models.
C430M	8/91	Rev. D. Sections 2.3, 2.4 and Figure 3 revised to include additional mounts; revised voltages, power consumption and cable distances; and revised wiring diagram for heater/blower.
	1/93	Addendum issued to include installation instructions for outdoor applications.
C430M-E	1/95	Rev. E. Revised to include new heater wattage values as per ECO #93-185, new component/assembly diagrams with updated BOM information as per ECO #93-187. Revised to show the removal of PC board when using blower kits only, with updated wiring diagrams, as per ECO #93-210. Incorporated the use of CAPU0050.00/25 in 24 VDC blower kit wiring, as per ECO #94-447. Indoor/outdoor installation instructions incorporated.
	9/95	Parts list updated to show revised number for item 13.

(This page intentionally left blank.)

**INSTALLATION/OPERATION MANUAL  
EH4014/EH4018 SERIES  
CAMERA ENCLOSURES**

**1.0 WARNINGS**

Prior to installation and use of this product, the following WARNINGS should be observed.

1. Installation and servicing should only be done by Qualified Service Personnel and conform to all Local codes.
2. Unless the unit is specifically marked as a NEMA Type 3-6P enclosure, it is designed for Indoor use only and it must not be installed where exposed to rain and moisture.
3. The product bears the following marks:
  4. Only use replacement parts recommended by PELCO.
  5. After replacement/repair of this unit's electrical components, conduct a resistance measurement between line and exposed parts to verify the exposed parts have not been connected to line circuitry.
  6. The installation method and materials should be capable of supporting four (4) times the weight of the enclosure, pan/tilt, camera, and lens combination.

**This symbol indicates that dangerous voltage constituting a risk of electric shock is present within this unit.**



**CAUTION:**  
TO REDUCE THE RISK OF ELECTRICAL SHOCK, DO NOT REMOVE COVER. NO USER-SERVICEABLE PARTS INSIDE. REFER SERVICING TO QUALIFIED SERVICE PERSONNEL.

**This symbol indicates that there are important operating and maintenance instructions in the literature accompanying this unit.**



**CAUTION:**  
RISK OF ELECTRIC SHOCK.  
DO NOT OPEN.

**Please thoroughly familiarize yourself with the information in this manual prior to installation and operation.**

## 2.0 SCOPE

The information contained within this manual covers the EH4014/EH4018 Series camera enclosures.

## 3.0 DESCRIPTION

The EH4014 and EH4018 light-duty camera enclosures are designed for use with 2/3" cameras and will accommodate fixed focal length lenses or motorized zoom lenses with or without auto-iris operation.

The EH4014 and EH4018 have been engineered for indoor and outdoor use when used in accordance with the installation instructions of this manual. They are of contemporary design for indoor applications and are fully sealed for outdoor applications.

These enclosures have a removable rear cap for easy access to the slide-out, camera mount, platform. The adjustable glands on the rear cap allow for easy installation and adjustments for cables and camera/lens. The removable front cap allows manual lens adjustments to be made without removing the camera/lens.

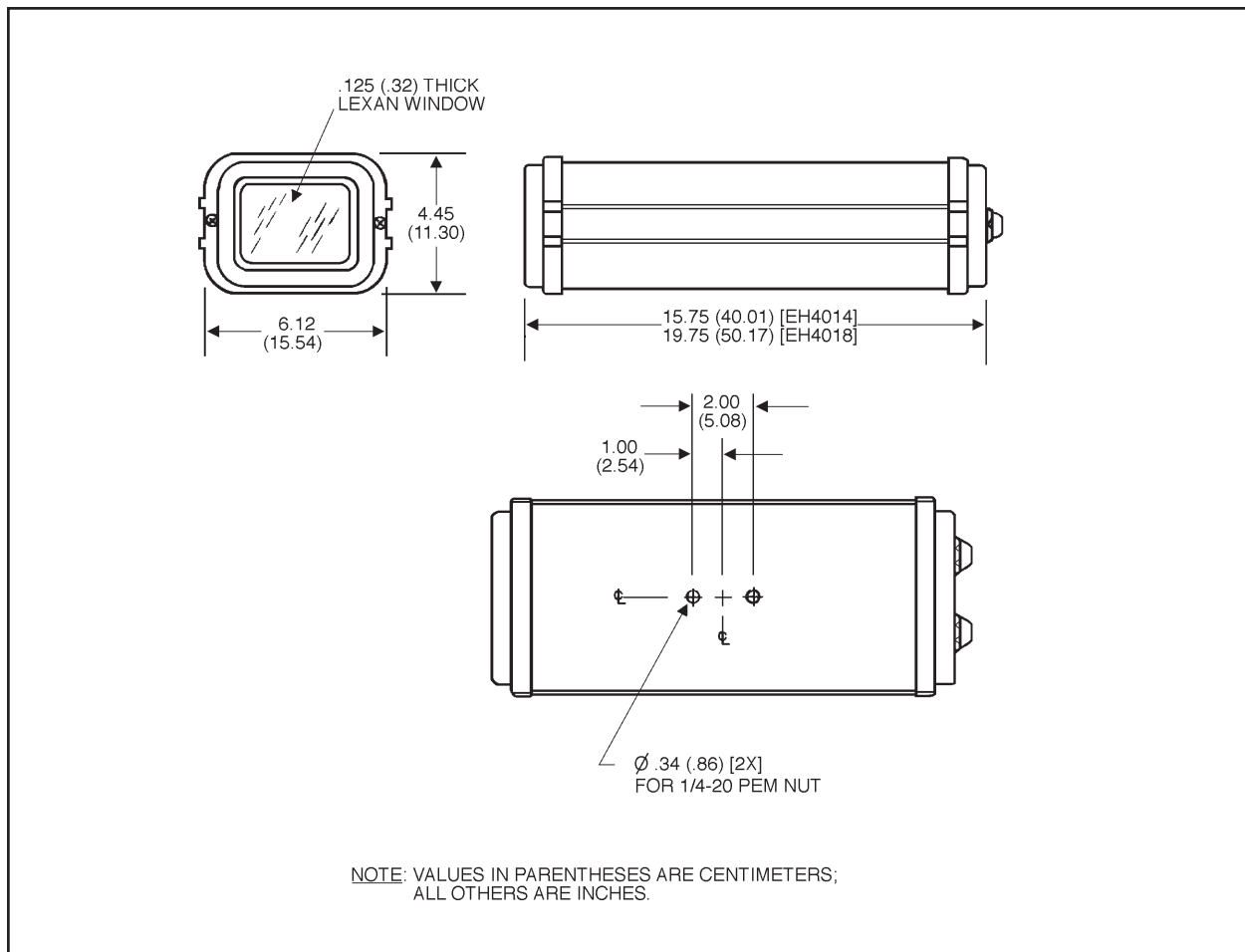

Figure 1. EH4014/EH4018 Dimension Drawing

### 3.1 MODELS

EH4014	Enclosure, indoor/outdoor extruded aluminum construction for 2/3" cameras and fixed focal length lenses up to 12" long. (UL, CE)
EH4014-1	Same as EH4014 except maximum camera/lens length is 10.25" and unit is supplied with 120 VAC heater/blower. (UL)
EH4014-2	Same as EH4014 except maximum camera/lens length is 10.25" and unit is supplied with 24 VAC heater/blower. (UL, CE)
EH4014-3	Same as EH4014 except maximum camera/lens length is 10.25" and unit is supplied with 230 VAC heater/blower. (CE)
EH4014/BR	Same as EH4014 with brass-plated finish.
EH4014/CH	Same as EH4014 except chrome plated finish.
EH4014/CP	Same as EH4014 except copper plated finish.
EH4018	Enclosure, indoor/outdoor extruded aluminum construction for 2/3" cameras and fixed focal length lenses up to 16" long. (UL, CE)
EH4018-1	Same as EH4018 except maximum camera/lens length is 14.25" and unit is supplied with 120 VAC heater/blower. (UL)
EH4018-2	Same as EH4018 except maximum camera/lens length is 14.25" and unit is supplied with 24 VAC heater/blower. (UL, CE)
EH4018-3	Same as EH4018 except maximum camera/lens length is 14.25" and unit is supplied with 230 VAC heater/blower. (CE)

**NOTE:** 230 VAC models are not listed by Underwriters Laboratories, Inc.

### 3.2 OPTIONS

AFW4000	Anti-fogging window
BK4000	Blower kit for EH4014/EH4018, 120 VAC, 4 watts
BK4024	Blower kit for EH4014/EH4018, 24 VAC, 3 watts
BK4220	Blower kit for EH4014/EH4018, 230 VAC, 4.8 watts
HK4014	Heater kit for EH4014/EH4018, 120 VAC, 40 watts. Activates ON at 40°F; OFF at 60°F
HK4024	Heater kit for EH4014/EH4018, 24 VAC, 40 watts. Activates ON at 40°F; OFF at 60°F
HK4220	Heater kit for EH4014/EH4018, 230 VAC, 30 watts. Activates ON at 40°F; OFF at 60°F
LK4000	Tamper-proof screw kit for EH4000 Series.
SS4014	Sun shroud for EH4014
SS4018	Sun shroud for EH4018

### 3.3 RECOMMENDED CABLE SIZE

**CAUTION:** When using a single power source for both the camera and accessories, the camera power consumption must be taken into consideration when determining wire gauge.

The following cable sizes are the minimum recommended for use with the combination of blower/heater/camera.

Power Model Number	Input Voltage	Consumption	Cable Size	Cable Distance
EH4014-1/ EH4018-1	120 VAC	44 watts	22 Awg 20 Awg 18 Awg 16 Awg	1,013 ft (308.8 m) 1,612 ft (491.3 m) 2,564 ft (781.5 m) 4,070 ft (1,240.5 m)
EH4014-2/ EH4018-2	24 VAC	43 watts	20 Awg 18 Awg 16 Awg 14 Awg	65 ft (19.8 m) 100 ft (30.48m) 165 ft (50.3 m) 265 ft (80.8 m)
EH4014-3/ EH4018-3	230 VAC	34.8 watts	20 Awg 18 Awg 16 Awg 14 Awg	7,488 ft (2,282 m) 11,913 ft (3631 m) 18,906 ft (5,763 m) 30,161 ft (9,193 m)
BK4000	120 VAC	4 watts	22 Awg 20 Awg 18 Awg 16 Awg	11,152 ft (3,399.1 m) 17,733 ft (5,405.0 m) 28,213 ft (8,599.3 m) 44,776 ft (13,647.7 m)
BK4024	24 VAC	3 watts	20 Awg 18 Awg 16 Awg 14 Awg	945 ft (288.0 m) 1,500 ft (457.2 m) 2,385 ft (726.9 m) 3,805 ft (1,159.8 m)
BK4220	230 VAC	4.8 watts	20 Awg 18 Awg 16 Awg 14 Awg	54,289 ft (16,547.5 m) 86,370 ft (26,326 m) 137,075 ft (41,780 m) 218,667 ft (66,650 m)
HK4014	120 VAC	40 watts	22 Awg 20 Awg 18 Awg 16 Awg	1,115 ft (339.9 m) 1,770 ft (539.5 m) 2,820 ft (859.5 m) 4,475 ft (1364.0 m)
HK4024	24 VAC	40 watts	20 Awg 18 Awg 16 Awg 14 Awg	70 ft (21.3 m) 110 ft (33.5 m) 175 ft (55.3 m) 285 ft (86.9 m)
HK4220	230 VAC	30 watts	20 Awg 18 Awg 16 Awg 14 Awg	8,686 ft (2,647 m) 13,819 ft (4,212 m) 21,932 ft (6,685 m) 34,986 ft (10,664 m)



### 3.4 SPECIFICATIONS

#### MECHANICAL

Camera  
Mounting: Multiple holes on camera sled

Camera Size: Accommodates camera/lens combinations up to:  
5.25" W x 3.50" H x

(EH4014)	12.00" L
(EH4018)	16.00" L
(EH4014-1/EH4014-2/EH4014-3)	10.25" L
(EH4018-1/EH4018-2/EH4018-3)	14.25" L

Viewing  
Window: 1/8" thick, optically clear, impact resistant Lexan (U.L. 94HB rated).  
Viewing area 2.50"H x 3.75"W.

Cable Entry: Two compression glands on rear cap

#### GENERAL

Construction: Extruded aluminum body; injection-molded ABS black plastic end caps

Finish: Textured, semigloss beige enamel (all models except /BR(brass), /CH (chrome), or /CP (copper))

Dimensions: See Figure 1

Weight:

EH4014	4 lbs. 4 oz. (1.91 kg)
EH4014-1	5 lbs. (2.25 kg)
EH4014-2	5 lbs. (2.25 kg)
EH4014-3	5 lbs. (2.25 kg)
EH4018	5 lbs. (2.25 kg)
EH4018-1	5 lbs. 12 oz. (2.59 kg)
EH4018-2	5 lbs. 12 oz. (2.59 kg)
EH4018-3	5 lbs. 12 oz. (2.59 kg)

Shipping  
Weight:

EH4014	6 lbs. (2.7 kg)
EH4014-1	6 lbs. 12 oz. (3.04 kg)
EH4014-2	6 lbs. 12 oz. (3.04 kg)
EH4014-3	6 lbs. 12 oz. (3.04 kg)
EH4018	7 lbs. (3.15 kg)
EH4018-1	7 lbs. 12 oz. (3.49 kg)
EH4018-2	7 lbs. 12 oz. (3.49 kg)
EH4018-3	7 lbs. 12 oz. (3.49 kg)

## 4.0 INSTALLATION

The following hardware is supplied with the enclosure and can be used to mount the enclosure or the camera/lens.

Quantity	Item
3	1/4-20 x .500 Hex head screws
3	1/4 Flat washers
3	1/4 Split washers

### 4.1 CAMERA/LENS INSTALLATION

To install the camera/lens, perform the following steps:

1. Remove the two (2) Phillips head screws from the rear cap.
2. Remove the rear cap from the enclosure, pull out the sled assembly and remove it from the rail.
3. Place the camera/lens on the sled assembly.

**NOTE:** Position the camera/lens at the forward-most point on the sled, while allowing clearance between the lens and enclosure window when the lens is adjusted to its maximum physical length.

4. Secure the camera/lens to the sled with the 1/4-20 hex head screws provided.
5. Pull the video and power cables through the glands and attach to the camera. Adjust the glands for a tight fit around the cables. The cable glands are designed to be used with a single cable ranging in size from 0.187" (0.475 cm) to 0.312" (792 cm) in diameter.
6. Adjust camera focus and iris if necessary.
7. Replace the sled on the rail and slide the assembly into the enclosure until the cap is securely closed.

8. Replace the two (2) Phillips head screws.

**IMPORTANT:** When reinstalling the front or rear of the enclosure, make sure the end caps are firmly seated against the enclosure to insure proper sealing.

9. Attach the enclosure to the appropriate mount or pan/tilt using the instructions provided.
10. If the housing is mounted such that the two mounting holes are facing up, and only one mounting hole is used, the other hole shall be plugged by a 1/4"-20 bolt to prevent the entrance of water.
11. All cables entering the enclosure shall employ a service loop to prevent the entrance of water.

**NOTE:** If the lens needs to be adjusted after installation, it is easier to remove the front cap to make final lens adjustments.

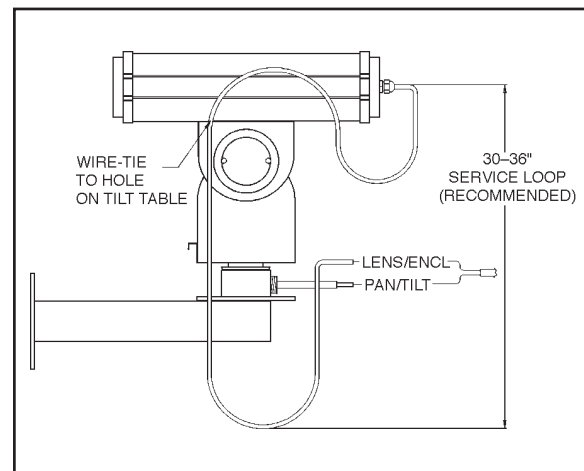

## 4.2 HEATER KIT INSTALLATION

Refer to Section 2.4, Recommended Cable Size, to determine cable size needed for installation. To install the heater and/or blower kits perform the following steps (refer to Figure 2):

1. Remove the Phillips head screws from the rear cap and slide the assembly out from the enclosure.
2. Attach the bracket with the terminal strip and heater thermostat to the rear plate using two (2) 6-32 self-tapping screws, mount onto the drilled-out holes.
3. Install the bracket with the heater pad onto the front of the sled using the 1/4-20 screw.
4. Wire according to the wiring diagram in Figure 3.

## 4.3 BLOWER KIT INSTALLATION

To install the BK4000/BK4024, perform the following steps:

1. Remove the Phillips Head screws from the rear cap and slide the assembly out from the enclosure.
2. Attach the blower assembly to the rear plate using two of the self-tapping screws holding the end cap to the sled.
3. Wire according to the wiring diagram in Figure 3.

**NOTE:** When used in conjunction with a heater kit, the blower can be wired into the terminal block on the P.C. Board.

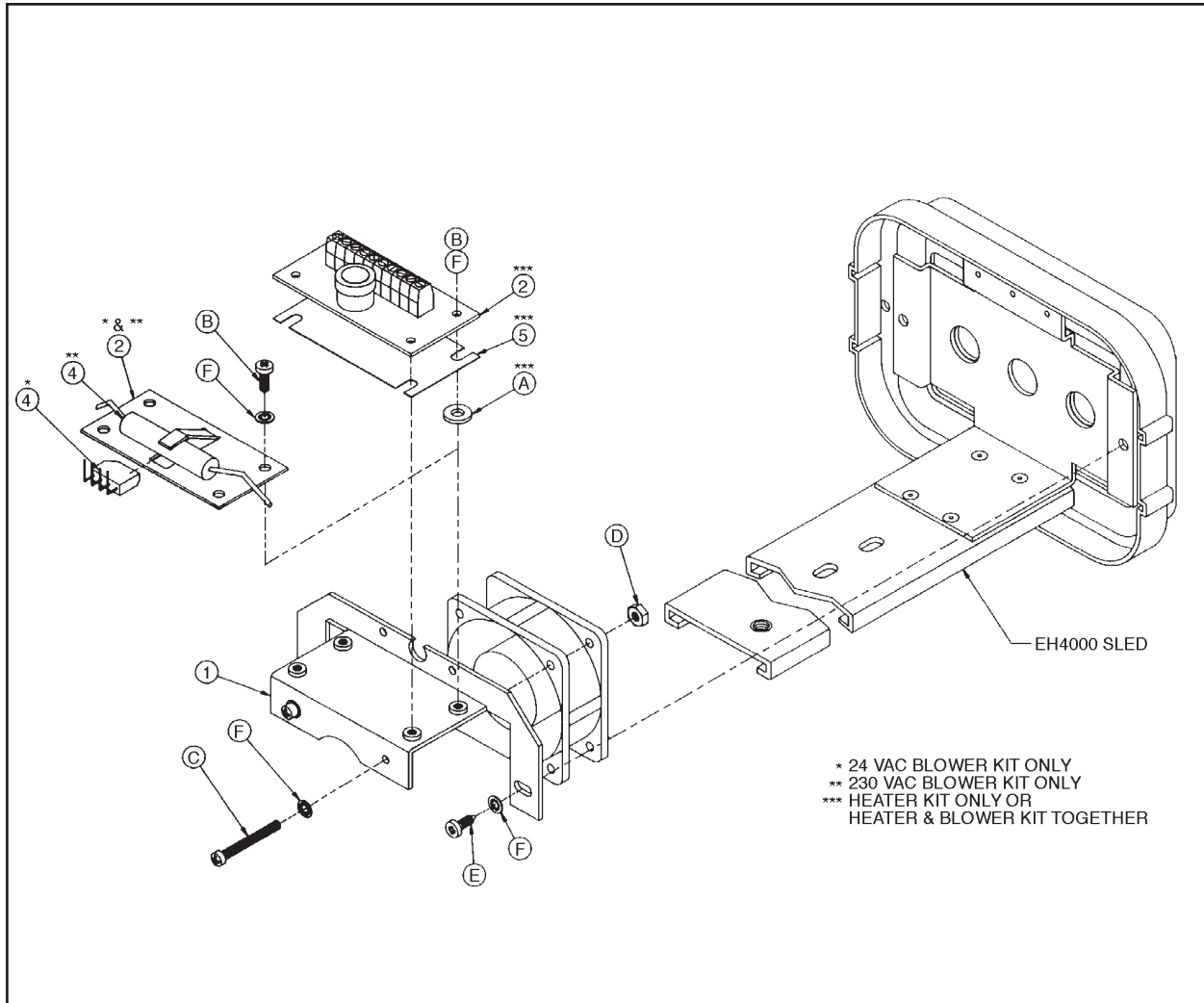
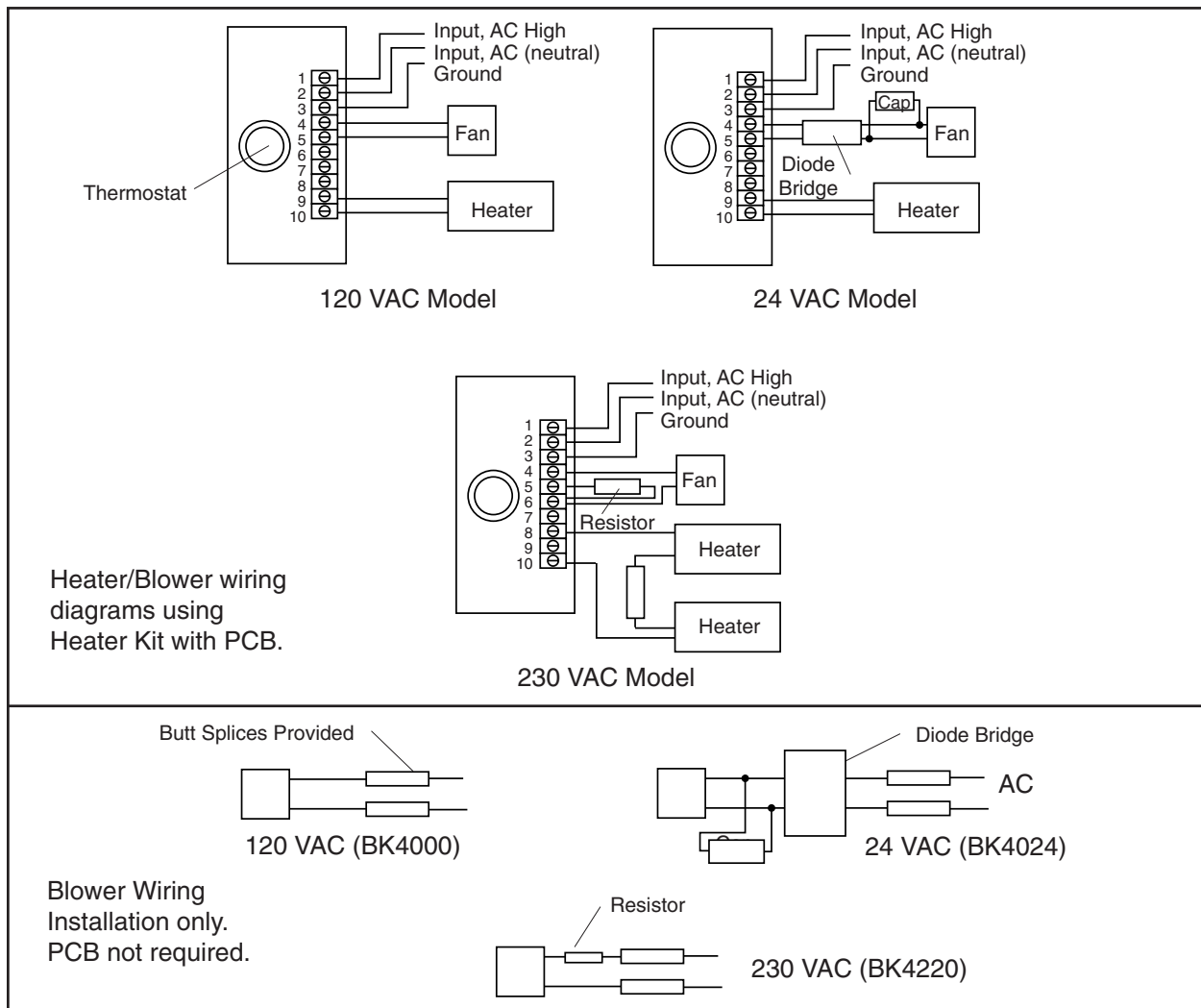

Figure 2. Heater Bracket and Blower Installation

#### 4.4 INSTALLATION PROCEDURES

The following items are supplied in the heater and blower kits.

Quantity	Item	PELCO Part No.	Blower Kit	Heater Kit
1	PCB and blower bracket	BK40004000COMP	X	X
1	PCB and thermostat assy (24V/120V)	PCB9000300ASSY		X
1	PCB and thermostat assy	PCB9100300ASSY		X
4	PCB mounting screws, 6-32 x 3/8	ZH6-32X.375SPP		X
4	PCB insulating washers	ZH200X437X62N		X
1	Heater bracket (24V/120V)	HK40244000COMP	24/120 VAC models	
1	Heater bracket (230V)	HK2304000COMP	230 VAC model	
1	Heater pad, 120V/40W	EHWD10087	120 VAC model	
1	Heater pad, 24V/40W	EHHK10087	24 VAC model	
2	Heater pad, 120V/15W	HK300010115	230 VAC model	
1	Heater bracket mounting screw	ZH1/420X.375SPP	All heater models	
1	Fan, 120 VAC, 19 CFM	MM750010003	120 & 230 VAC models	
1	Fan, 24 VDC, 19 CFM	ED210005	24 VAC model	
1	Resistor for fan, 3K ohm	RES003.0K10.0	230 VAC model	
1	Bridge Rectifier Diode	DIOMDA104	24 VAC model	
1	Capacitor	CAPU0050.0/25	24 VAC model	
1	Component Bracket	BK7044002COMP	24 & 230 VAC models	



**Figure 3.** Heater/Blower Wiring Diagram

## 4.5 SUN SHROUD INSTALLATION

The sun shroud protects the enclosure from the direct rays of the sun and reduces internal temperature by approximately 10-15°. To install the sun shroud, perform the following steps (refer to Figure 4).

1. Remove the two (2) screws from the front or rear end cap of the enclosure.
2. Remove the cap.
3. Align the guides on the sun shroud with the runner on the enclosure.
4. Slide the sun shroud until the bottom guides on the sun shroud meet the opposite end cap.

5. Put the cap back on the enclosure and fasten down with the screws.

**NOTE:** Be sure the screws are tightened down to secure the seal between the cap and the enclosure.

## 5.0 CARE AND MAINTENANCE

Regularly scheduled maintenance will help prolong the operational life and appearance of the equipment. Clean the window regularly with a mild nonabrasive detergent in water and with a soft cloth to help maintain picture clarity.

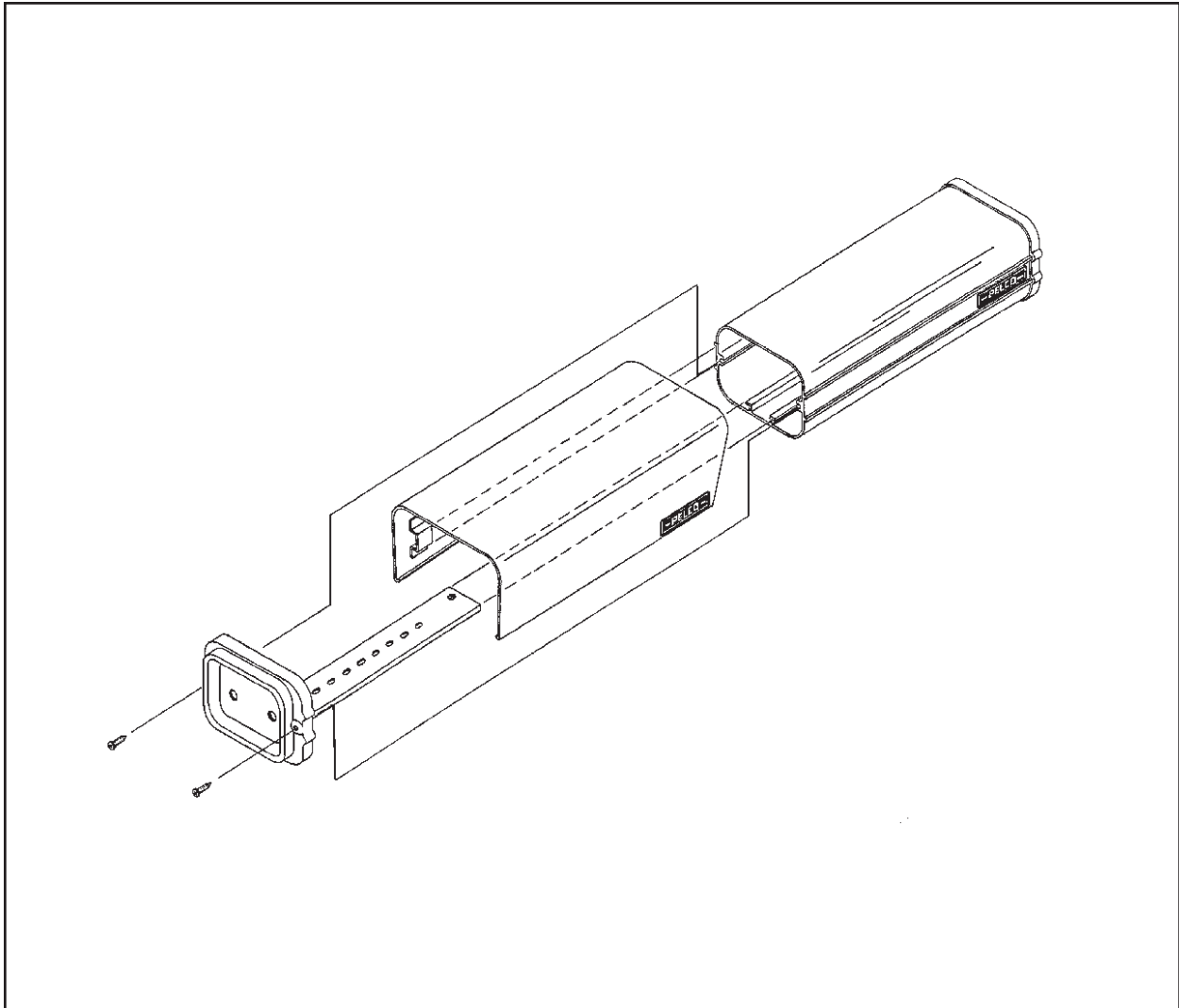

Figure 4. Sun Shroud Installation

## 6.0 EXPLODED ASSEMBLY DIAGRAM/ PARTS LIST

The following parts list corresponds to the exploded assembly diagram in Figure 5.

Item	Quantity	Description	Part Number
1	2	Gasket, front/rear (not shown)	EH400010000
2	1	Front cap, black	EH400010006
3	2	Gland, SL9	EH400010003
4	2	Counter nut, GMP-9	EH400010004
5	1	Sled bracket	EH40004007COMP
6	1	Rear end cap, black	EH400010005
7	1	Body, 14" enclosure (EH4014 only)	EH40144000COMP
	1	Body, 18" enclosure (EH4018 only)	EH40184000COMP
8	1	Sled (EH4014)	EH40144001COMP
	1	Sled (EH4018)	EH40184001COMP
9	4	Screw, 8-32 x .500, pan head, Phil SS	ZH8-32X.500SPP
10	7	Screw, #8 x 1/2" Type A, Pan, Phil SS	ZH8-SBTX.500SPP
11	4	Washer, flat, 3/16 USS spl-size pltd	ZH260X562X65C
12	1	Window, 4.453"W x 3.031"H x .125" thick (Lexan)	EH400010009
13	2	NP gasket 1/8 x 1/8 ft (not shown)	EH110042
14	2	Screw, 1/4-20 x 1/2" hex cad C/S SS (not shown)	ZH1/4-20X.500CH
15	1	Screw, 1/4-20 x 3/8" pan, Phil SS (not shown)	ZH1/420X.375SPP
16	1	Washer, internal star 1/4" SS (not shown)	ZH1/4LWSIS
17	2	Washer, split lock 1/4" SS (not shown)	ZH1/4LWSSL
18	4	Screw, 6-32 x 3/8" Type F Phil Pan SS (not shown)	ZH6-SFX.375SPP
19	1	Installation kit, enclosure hardware (not shown)	IK1000

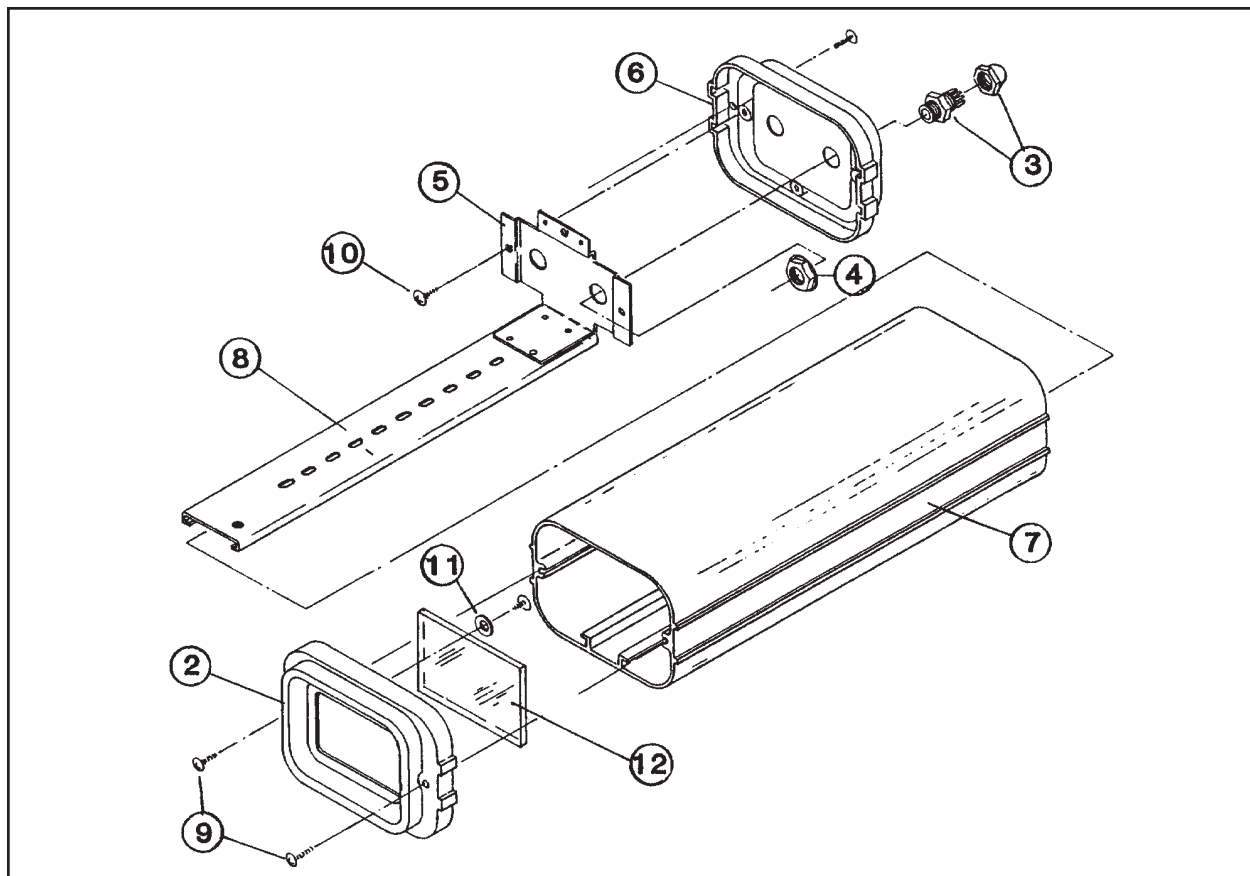

Figure 5. EH4014/EH4018 Exploded Assembly Diagram

## 7.0 WARRANTY AND RETURN INFORMATION

### WARRANTY

Pelco will repair or replace, without charge, any merchandise proved defective in material or workmanship for a period of one year after the date of shipment.

Exceptions to this warranty are as noted below:

- Five years on FT/FR8000 Series fiber optic products.
- Three years on Genex® Series products (multiplexers, server, and keyboard).
- Three years on Camclosure® and fixed camera models, except the CC3701H-2, CC3701H-2X, CC3751H-2, CC3651H-2X, MC3651H-2, and MC3651H-2X camera models, which have a five-year warranty.
- Two years on standard motorized or fixed focal length lenses.
- Two years on Legacy®, CM6700/CM6800/CM9700 Series matrix, and DF5/DF8 Series fixed dome products.
- Two years on Spectra®, Esprit®, ExSite™, and PS20 scanners, including when used in continuous motion applications.
- Two years on Esprit® and WW5700 Series window wiper (excluding wiper blades).
- Eighteen months on DX Series digital video recorders, NVR300 Series network video recorders, and Endura™ Series distributed network-based video products.
- One year (except video heads) on video cassette recorders (VCRs). Video heads will be covered for a period of six months.
- Six months on all pan and tilts, scanners or preset lenses used in continuous motion applications (that is, preset scan, tour and auto scan modes).

Pelco will warrant all replacement parts and repairs for 90 days from the date of Pelco shipment. All goods requiring warranty repair shall be sent freight prepaid to Pelco, Clovis, California. Repairs made necessary by reason of misuse, alteration, normal wear, or accident are not covered under this warranty.

Pelco assumes no risk and shall be subject to no liability for damages or loss resulting from the specific use or application made of the Products. Pelco's liability for any claim, whether based on breach of contract, negligence, infringement of any rights of any party or product liability, relating to the Products shall not exceed the price paid by the Dealer to Pelco for such Products. In no event will Pelco be liable for any special, incidental or consequential damages (including loss of use, loss of profit and claims of third parties) however caused, whether by the negligence of Pelco or otherwise.

The above warranty provides the Dealer with specific legal rights. The Dealer may also have additional rights, which are subject to variation from state to state.

If a warranty repair is required, the Dealer must contact Pelco at (800) 289-9100 or (559) 292-1981 to obtain a Repair Authorization number (RA), and provide the following information:

1. Model and serial number
2. Date of shipment, P.O. number, Sales Order number, or Pelco invoice number
3. Details of the defect or problem If there is a dispute regarding the warranty of a product which does not fall under the warranty conditions stated above, please include a written explanation with the product when returned.

Method of return shipment shall be the same or equal to the method by which the item was received by Pelco.

### RETURNS

In order to expedite parts returned to the factory for repair or credit, please call the factory at (800) 289-9100 or (559) 292-1981 to obtain an authorization number (CA number if returned for credit, and RA number if returned for repair).

All merchandise returned for credit may be subject to a 20% restocking and refurbishing charge.

Goods returned for repair or credit should be clearly identified with the assigned CA or RA number and freight should be prepaid. Ship to the appropriate address below.

If you are located within the continental U.S., Alaska, Hawaii or Puerto Rico, send goods to:

Service Department  
Pelco  
3500 Pelco Way  
Clovis, CA 93612-5699

If you are located outside the continental U.S., Alaska, Hawaii or Puerto Rico and are instructed to return goods to the USA, you may do one of the following:

If the goods are to be sent by a COURIER SERVICE, send the goods to:

Pelco  
3500 Pelco Way  
Clovis, CA 93612-5699 USA

If the goods are to be sent by a FREIGHT FORWARDER, send the goods to:

Pelco c/o Expeditors  
473 Eccles Avenue  
South San Francisco, CA 94080 USA  
Phone: 650-737-1700  
Fax: 650-737-0933



**PELCO**

3500 Pelco Way • Clovis, CA 93612-5699 • [www.pelco.com](http://www.pelco.com)  
(559) 292-1981 • (800) 289-9100 • FAX (559) 292-3827 or (800) 289-9150

International customers call 1-559-292-1981 or FAX 1-559-348-1120

*(Product specifications subject to change without notice.)*